

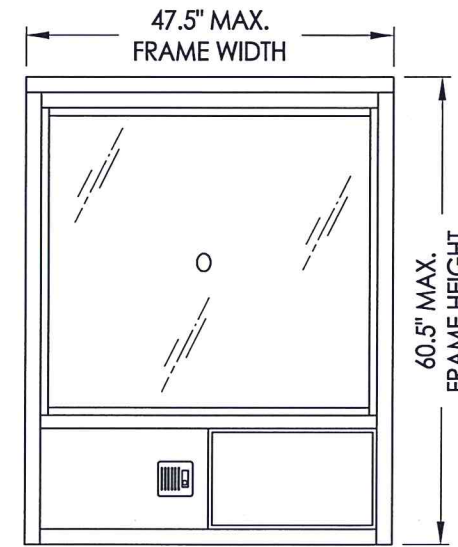

1815 Arthur Drive ■ West Chicago, Illinois 60185

READY ACCESS DRIVE THROUGH WINDOW "NON-IMPACT"



604 SERIES WINDOW

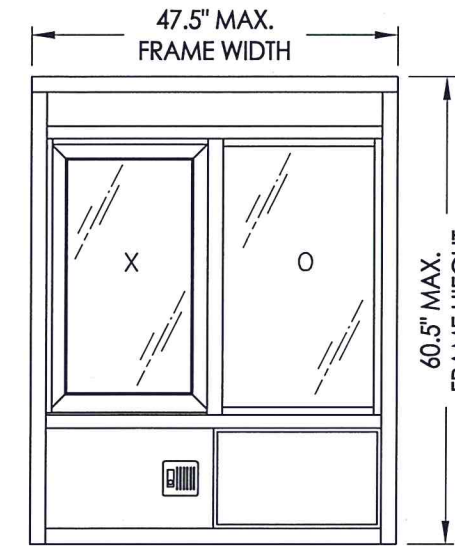

602 SERIES WINDOW

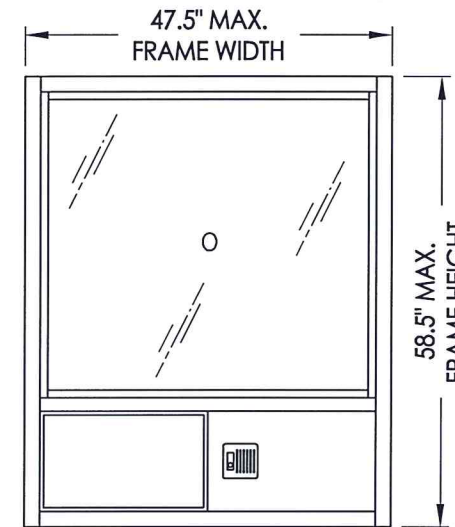

603 SERIES WINDOW

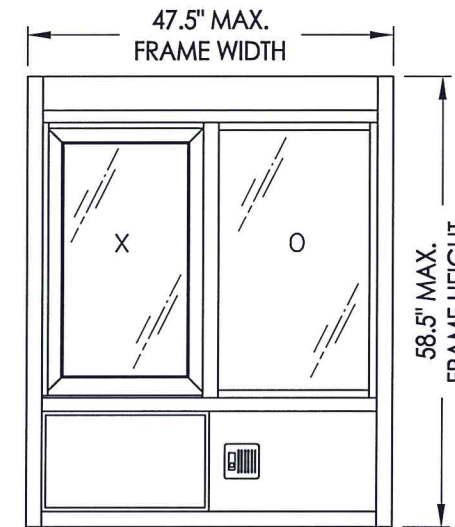

601 SERIES WINDOW

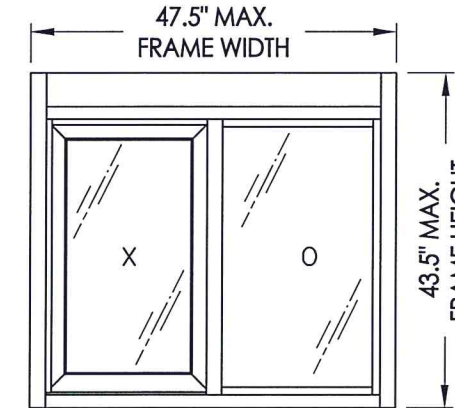

600 SERIES WINDOW

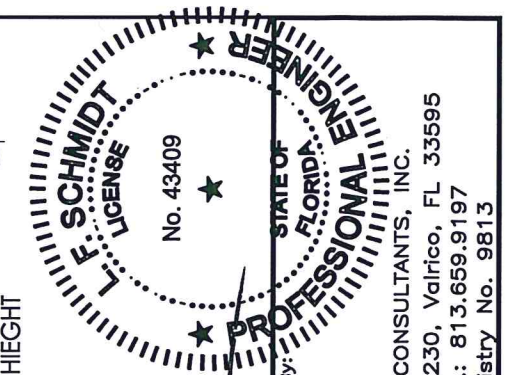

August 7, 2020

Documents Prepared By:
Lyndon F. Schmidt
P.E. No. 4-3409

R.W. BUILDING CONSULTANTS, INC.
P.O. Box 230, Valrico, FL 33595
Phone No.: 813.659.9197
FBPE Registry No. 9813

GENERAL NOTES

1. This product has been evaluated and is in compliance with the 7th Edition (2020) Florida Building Code (FBC) structural requirements including the "High Velocity Hurricane Zone" (HVHZ).
2. Product anchors shall be as listed and spaced as shown on details. Anchor embedment to base material shall be beyond wall dressing or stucco.
3. When used in the "HVHZ", this product is required to be protected with an impact resistant covering that complies with FBC Section 1626.
4. For 2x stud framing construction, anchoring of these units shall be the same as that shown for 2x buck masonry construction.
5. Wood bucks, by others, must be anchored properly to transfer loads to the structure.
6. This product meets the water requirements for the "HVHZ".
7. Aluminum components, including fasteners, shall meet the requirements of FBC Section 2003.
8. Site conditions that deviate from the details of this drawing require further engineering analysis by a licensed engineer or registered architect.

TABLE OF CONTENTS	
SHEET #	DESCRIPTION
1	Typical elevations, design pressures & general notes
2	600 Series window sections & details
3	601 Series window sections & details
4	602 Series window sections & details
5	603 Series window sections & details
6	604 Series window sections & details
7	Anchoring
8	Components
9	Bill of materials, components & glazing details

MODEL	OVERALL FRAME DIMENSION	OVERALL D.L.O. DIMENSION	GLASS TYPE	DESIGN PRESSURE RATING (PSF)			
				WHEN WATER INFILTRATION REQ'D		WHEN WATER INFILTRATION NOT REQ'D	
600	47.5" x 43.5"	(O) 19.62" x 33.78" (X) 16.14" x 30.18"	G1	+42.0	-42.0	+75.0	-75.0
601	47.5" x 58.5"	(O) 19.62" x 33.78" (X) 16.14" x 30.18"		+42.0	-42.0	+75.0	-75.0
602	47.5" x 60.5"	(O) 19.62" x 33.78" (X) 16.14" x 30.18"		+42.0	-42.0	+75.0	-75.0
603	47.5" x 58.5"	(O) 41.49" x 37.78"		+42.0	-42.0	+75.0	-75.0
604	47.5" x 60.5"	(O) 41.49" x 37.78"		+42.0	-42.0	+75.0	-75.0

PRODUCT: READY ACCESS DRIVE THROUGH WINDOW "NON-IMPACT"

PART OR ASSEMBLY: TYPICAL ELEVATIONS, DESIGN PRESSURES & GENERAL NOTES

NO.	DATE	BY	REVISIONS
3	8/07/20	LFS	UPDATE TO 7TH ED. (2020) FBC
2	7/13/17	LFS	UPDATE TO 6TH ED. (2017) FBC
1	3/30/15	LFS	UPDATE TO 5TH ED. (2014) FBC

DATE: 1/24/12
SCALE: N.T.S.
DWG. BY: KV
CHK. BY: LFS
DRAWING NO.: FL-5102.4
SHEET 1 OF 9

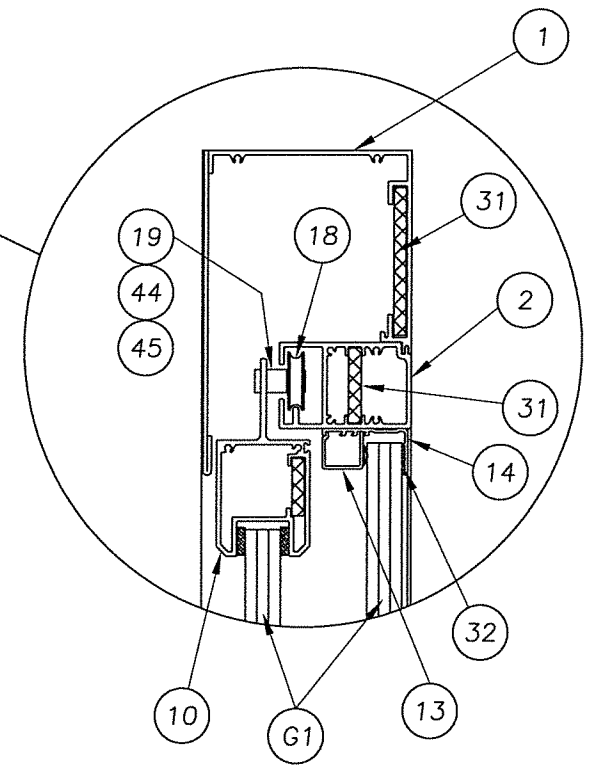
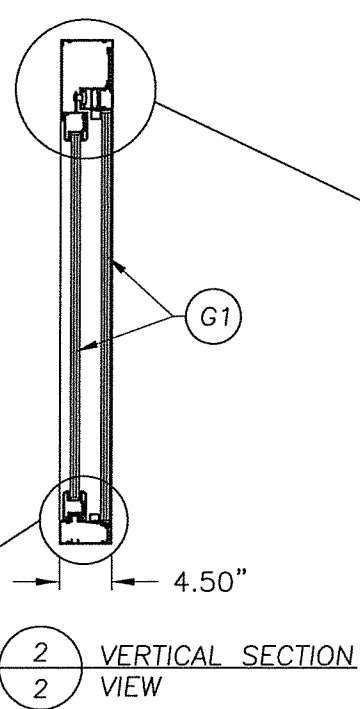
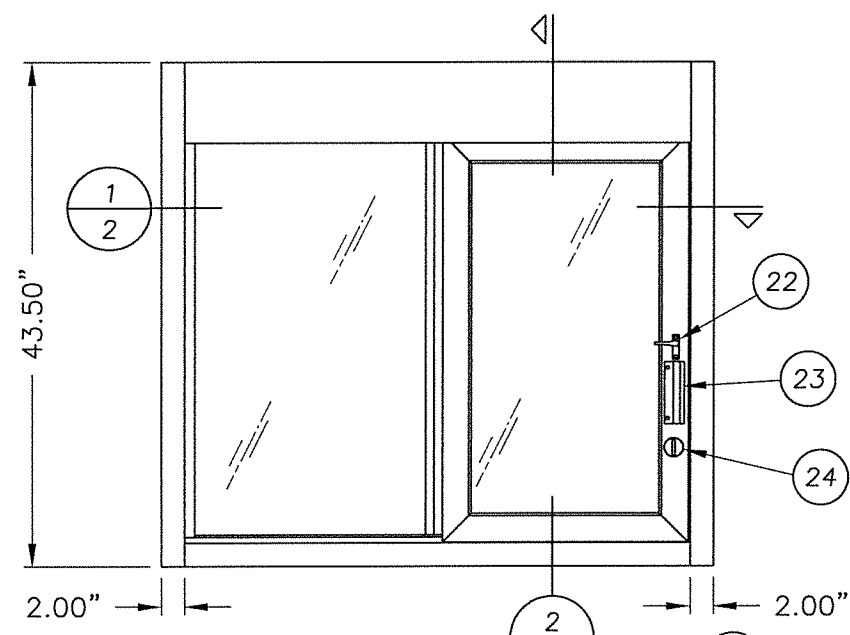
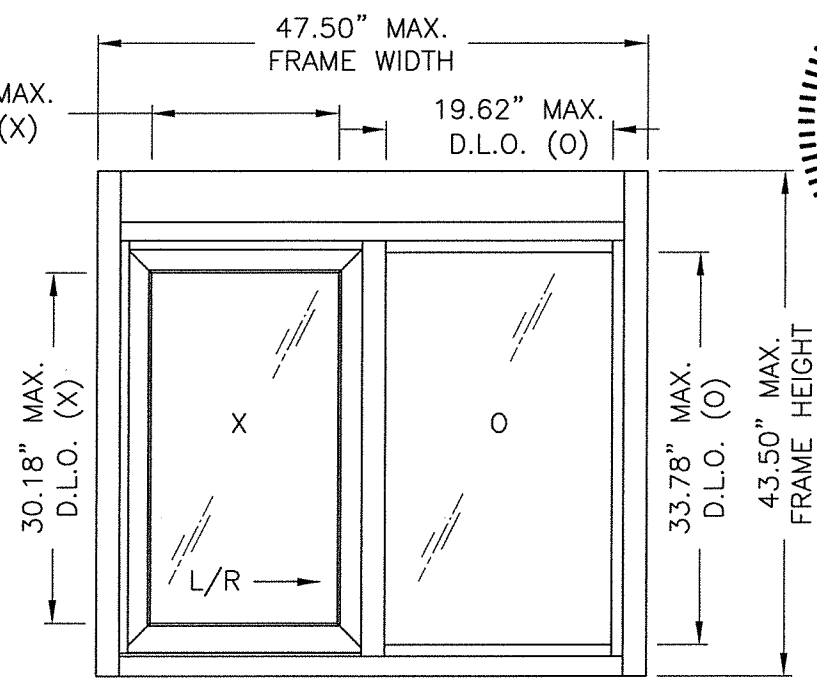
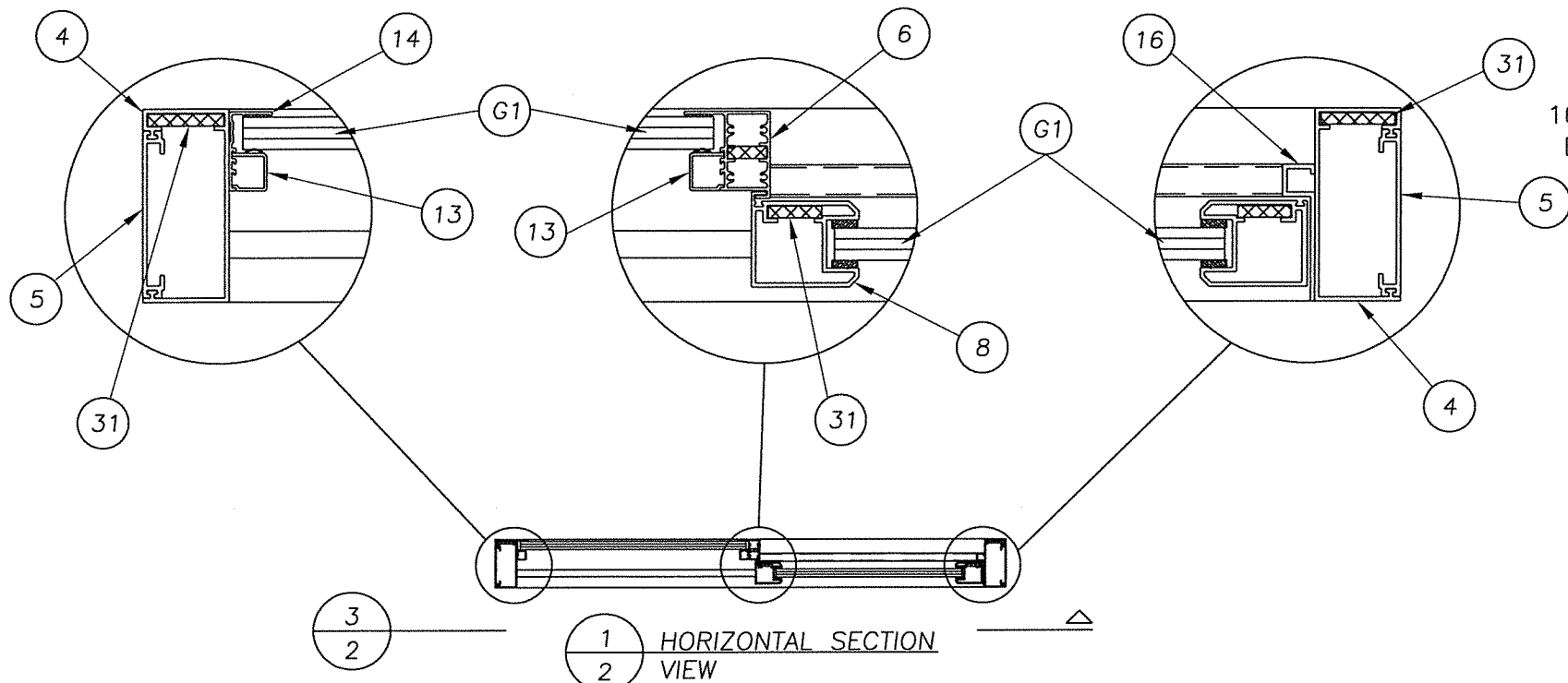

August 7, 2020
 Documents Prepared By:
 Lyndon F. Schmidt
 P.E. No. 43409

R.W. BUILDING CONSULTANTS, INC.
 P.O. Box 230, Valrico, FL 33595
 Phone No.: 813.659.9197
 FBPE Registry No. 9813

PRODUCT:		READY ACCESS DRIVE THROUGH WINDOW	
		"NON-IMPACT"	
PART OR ASSEMBLY:		600 SERIES WINDOW SECTIONS & DETAILS	
NO.	DATE	BY	REVISIONS
3	8/07/20	LFS	UPDATE TO 7TH ED. (2020) FBC
2	7/13/17	LFS	UPDATE TO 6TH ED. (2017) FBC
1	3/30/15	LFS	UPDATE TO 5TH ED. (2014) FBC
DATE: 1/24/12			
SCALE: N.T.S.			
DWG. BY: KV			
CHK. BY: LFS			
DRAWING NO.: FL-5102.4			
SHEET 2 OF 9			

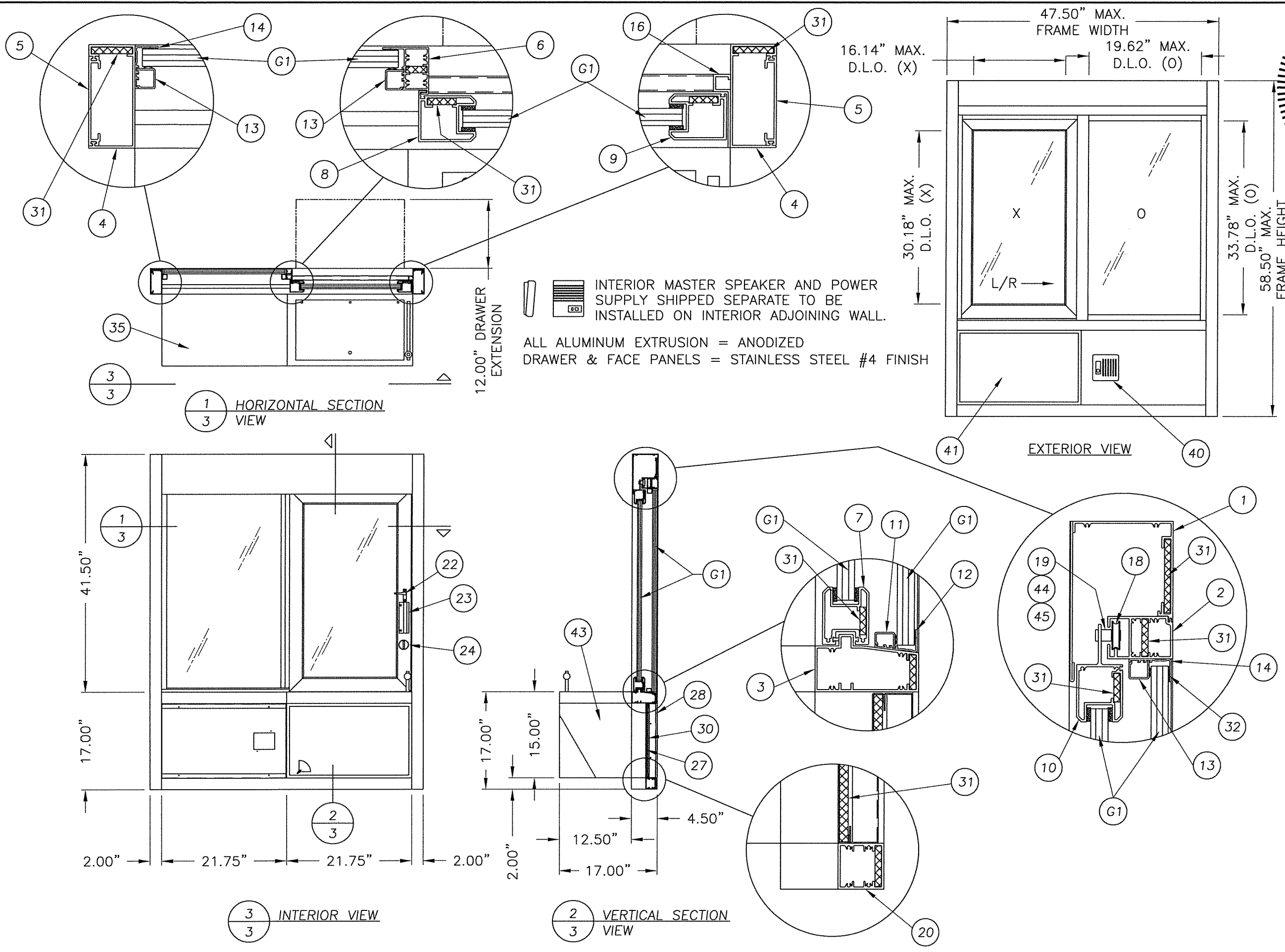

August 7, 2020
 Documents Prepared By:
 Lyndon F. Schmidt
 P.E. No. 43409

R.W. BUILDING CONSULTANTS, INC.
 P.O. Box 230, Valrico, FL 33595
 Phone No.: 813.659.9197
 FBPE Registry No. 9813

PRODUCT:		READY ACCESS DRIVE THROUGH WINDOW "NON-IMPACT"	
PART OR ASSEMBLY:		601 SERIES WINDOW SECTIONS & DETAILS	
NO.	DATE	BY	REVISIONS
3	8/07/20	LFS	UPDATE TO 7TH ED. (2020) FBC
2	7/13/17	FBC	UPDATE TO 6TH ED. (2017) FBC
1	3/30/15	FBC	UPDATE TO 5TH ED. (2014) FBC
DATE: 1/24/12			
SCALE: N.T.S.			
DWG. BY: KV			
CHK. BY: LFS			
DRAWING NO.: FL-5102.4			
SHEET 3 OF 9			

R:\Clients\Ready Access Perms\A - Florida Product Approvals\FL-5102 - Pass Through Windows\C - Drawings\FL 5102 (2020)\FL-5102.3-4.dwg, 4.4

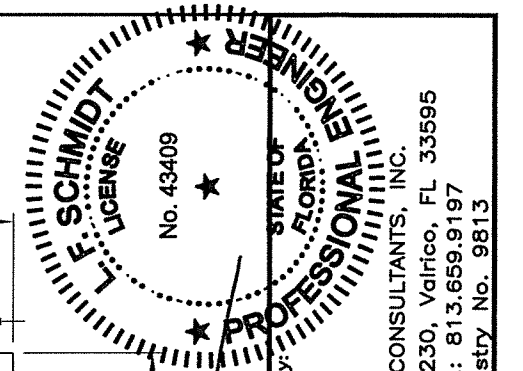
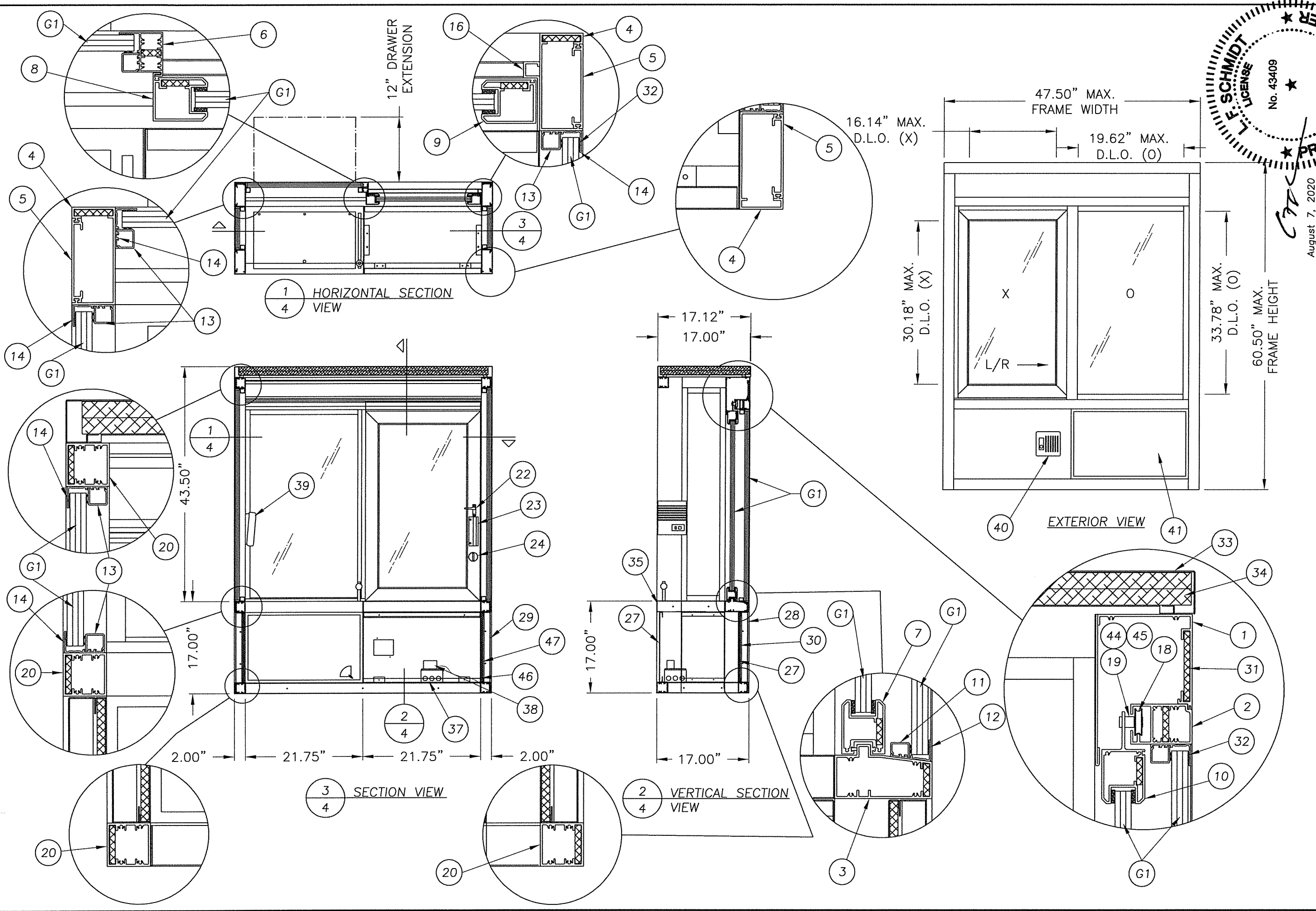



August 7, 2020
 Documents Prepared By: Lyndon F. Schmidt
 P.E. No. 43409
 R.W. BUILDING CONSULTANTS, INC.
 P.O. Box 230, Valrico, FL 33595
 Phone No.: 813.659.9197
 FBPE Registry No. 9813

PRODUCT: READY ACCESS DRIVE THROUGH WINDOW "NON-IMPACT"
 PART OR ASSEMBLY: 602 SERIES WINDOW SECTIONS & DETAILS

NO.	DATE	REVISIONS
3	8/07/20	UPDATE TO 7TH ED. (2020) FBC LFS
2	7/13/17	UPDATE TO 6TH ED. (2017) FBC LFS
1	3/30/15	UPDATE TO 5TH ED. (2014) FBC LFS
		BY

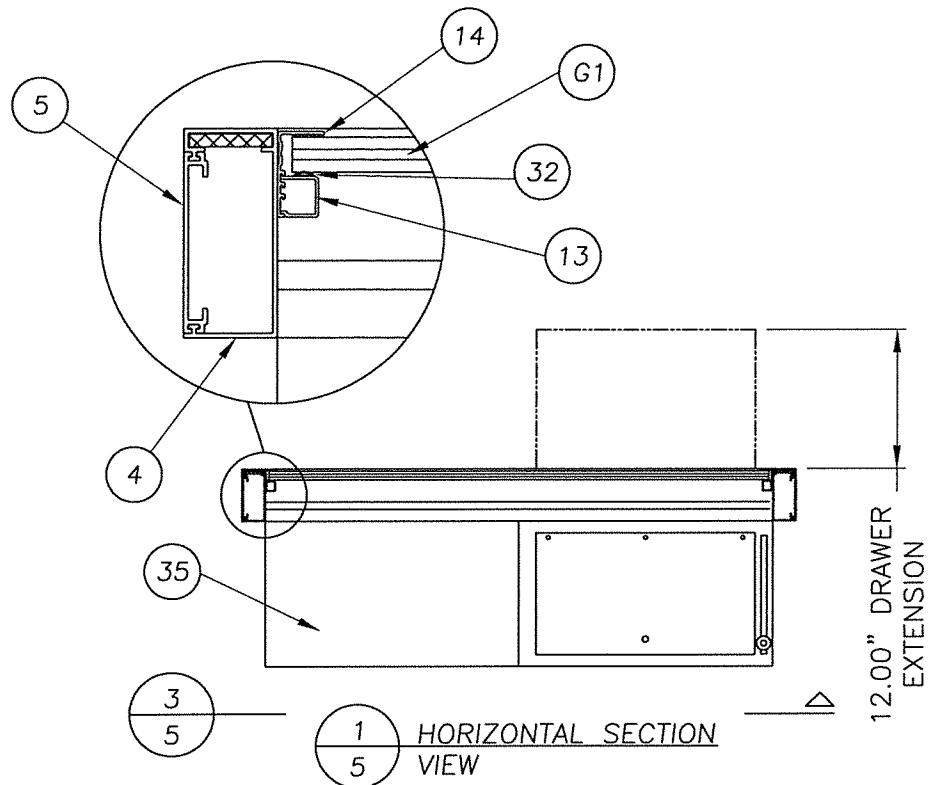
DATE: 1/24/12
 SCALE: N.T.S.
 DWG. BY: KV
 CHK. BY: LFS
 DRAWING NO.: FL-5102.4
 SHEET 4 OF 9



  INTERIOR MASTER SPEAKER AND POWER SUPPLY SHIPPED SEPARATE TO BE INSTALLED ON INTERIOR ADJOINING WALL.

ALL ALUMINUM EXTRUSION = ANODIZED
DRAWER & FACE PANELS = STAINLESS STEEL #4 FINISH

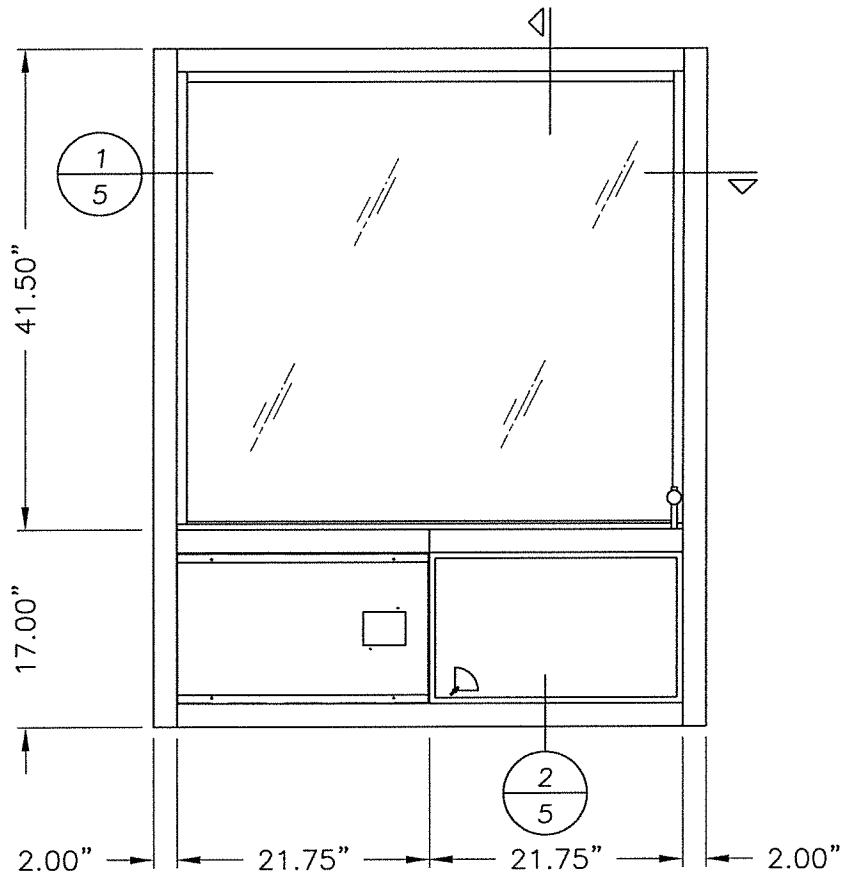

3
5 INTERIOR VIEW

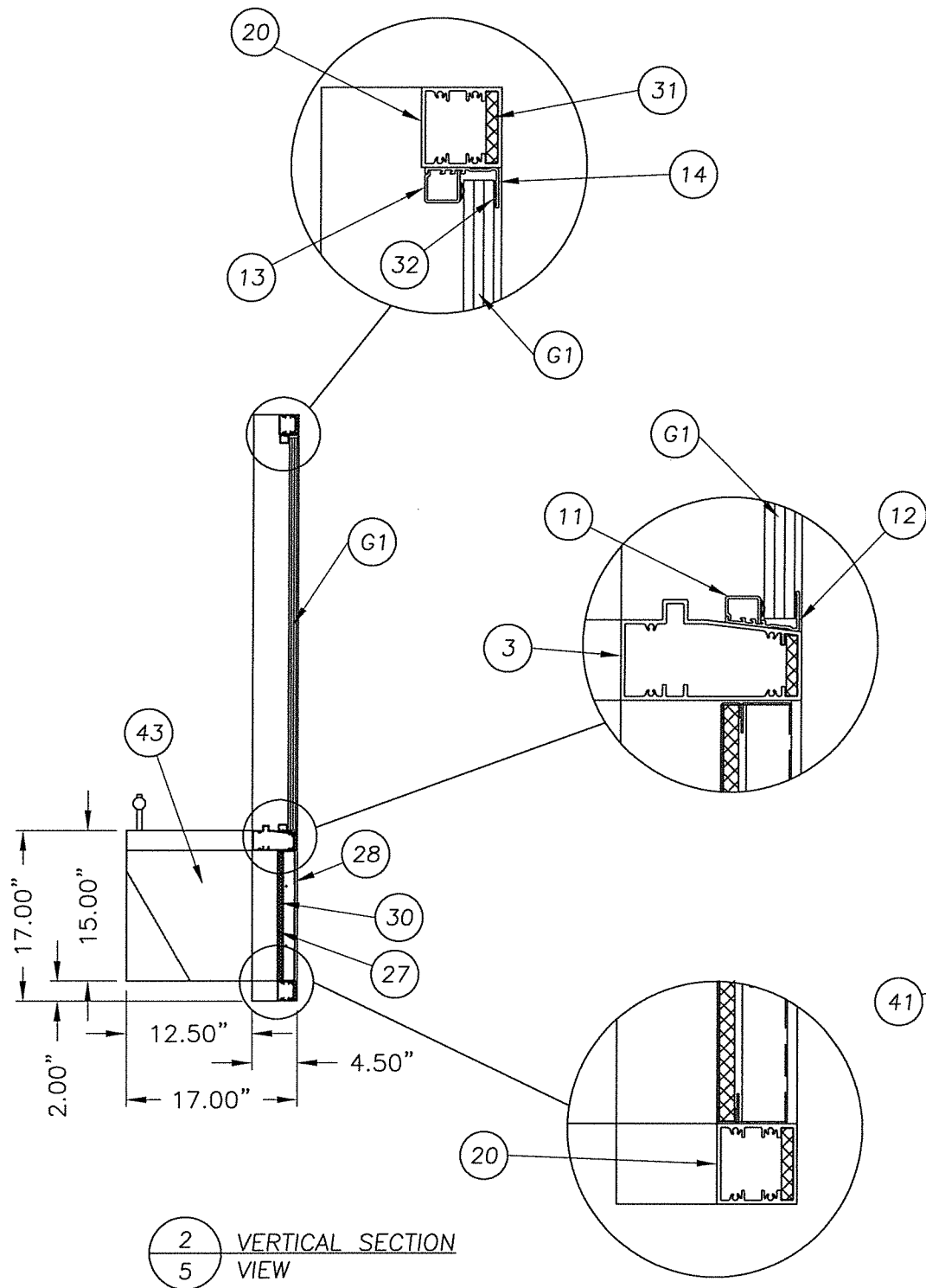

2
5 VERTICAL SECTION VIEW

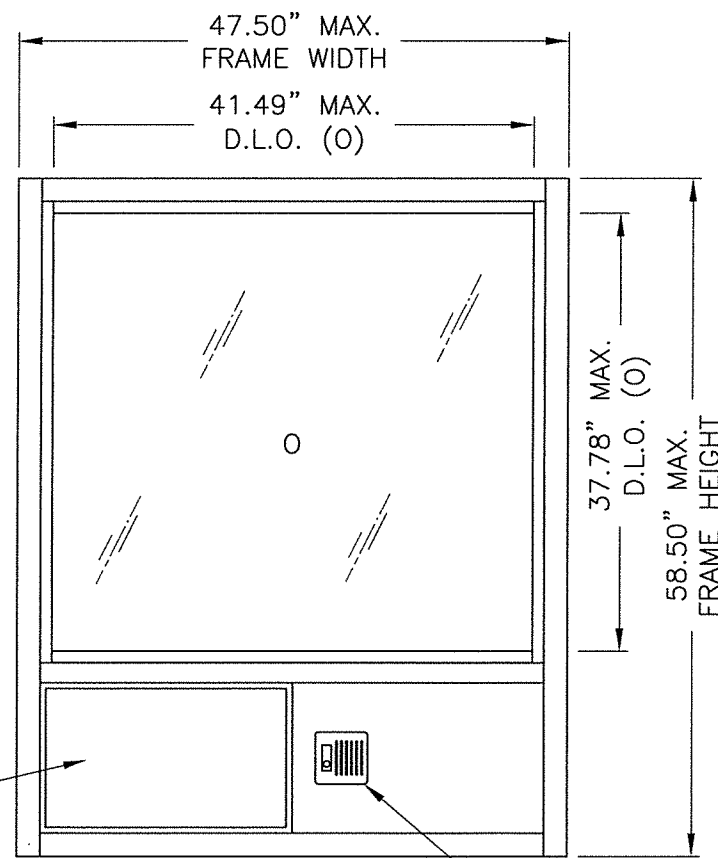

EXTERIOR VIEW

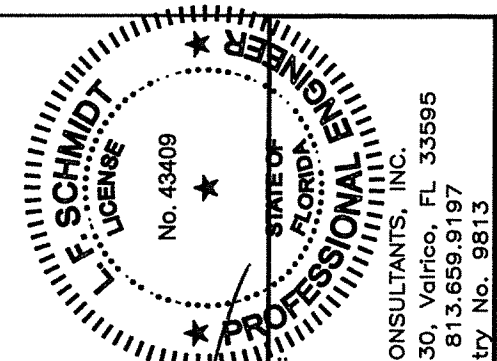

August 7, 2020

Documents Prepared By:
Lyndon F. Schmidt
P.E. No. 43409

RW BUILDING CONSULTANTS, INC.
P.O. Box 230, Valrico, FL 33595
Phone No.: 813.659.9197
FBPE Registry No. 9813

PRODUCT: READY ACCESS DRIVE THROUGH WINDOW "NON-IMPACT"
PART OR ASSEMBLY: 603 SERIES WINDOW SECTIONS & DETAILS

NO.	DATE	REVISIONS	BY
3	8/07/20	UPDATE TO 7TH ED. (2020) FBC	LFS
2	7/13/17	UPDATE TO 6TH ED. (2017) FBC	LFS
1	3/30/15	UPDATE TO 5TH ED. (2014) FBC	LFS

DATE: 1/24/12

SCALE: N.T.S.

DWG. BY: KV

CHK. BY: LFS

DRAWING NO.:

FL-5102.4

SHEET 5 OF 9

R:\Clients\Ready Access Perms\A - Florida Product Approvals\FL-5102 - Pass Through Windows\C - Drawings\FL 5102 (2020)\FL-5102.3-4.dwg, 4.6

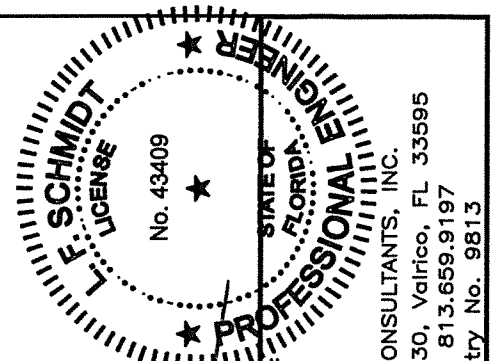
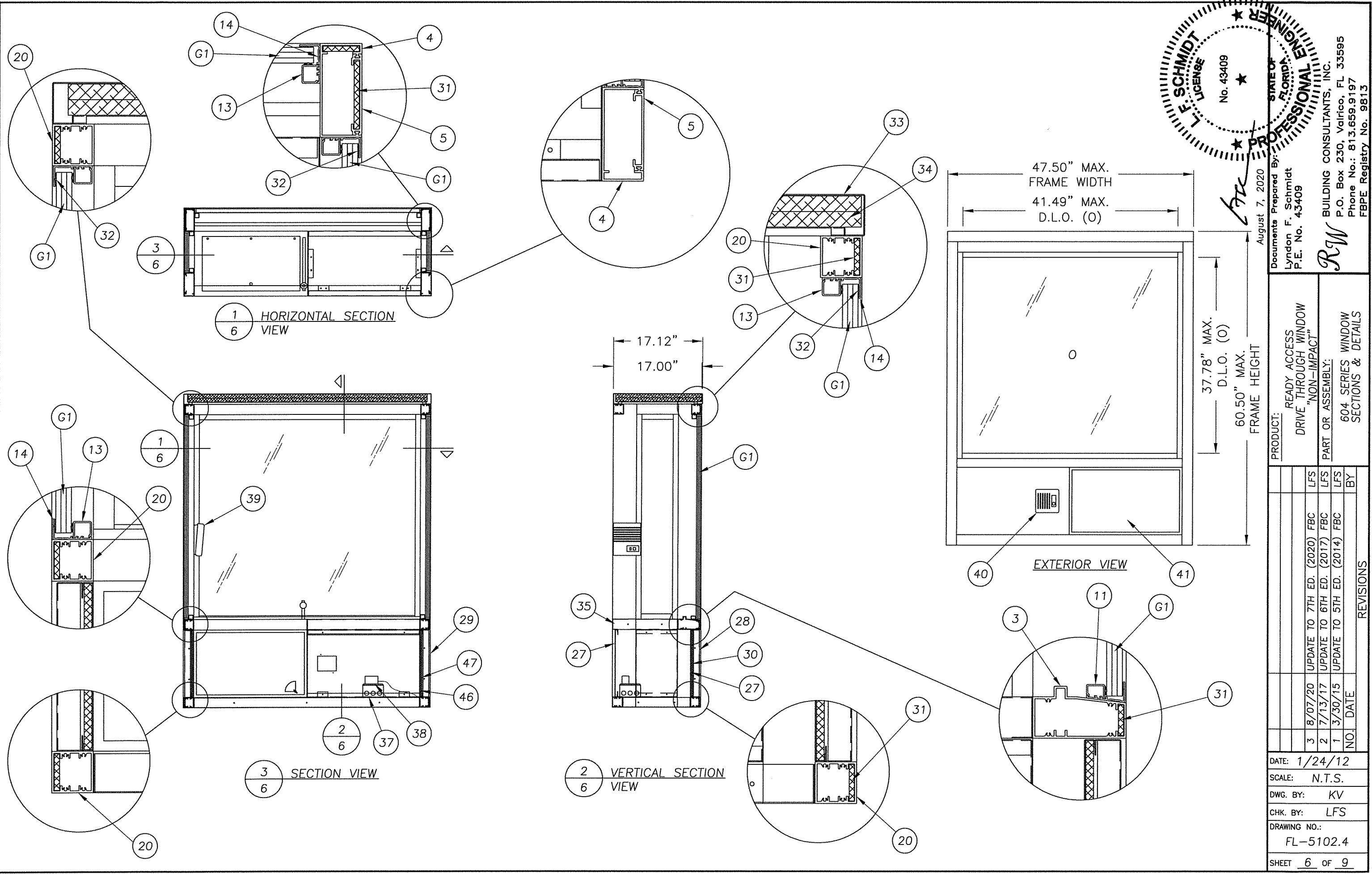

August 7, 2020
 Documents Prepared By:
 Lyndon F. Schmidt
 P.E. No. 43409

RW BUILDING CONSULTANTS, INC.
 P.O. Box 230, Valrico, FL 33595
 Phone No.: 813.659.9197
 FBPE Registry No. 9813

PRODUCT: READY ACCESS DRIVE THROUGH WINDOW "NON-IMPACT"
 PART OR ASSEMBLY: 604 SERIES WINDOW SECTIONS & DETAILS

NO.	DATE	REVISIONS
3	8/07/20	UPDATE TO 7TH ED. (2020) FBC LFS
2	7/13/17	UPDATE TO 6TH ED. (2017) FBC LFS
1	3/30/15	UPDATE TO 5TH ED. (2014) FBC LFS

DATE: 1/24/12
 SCALE: N.T.S.
 DWG. BY: KV
 CHK. BY: LFS
 DRAWING NO.: FL-5102.4
 SHEET 6 OF 9

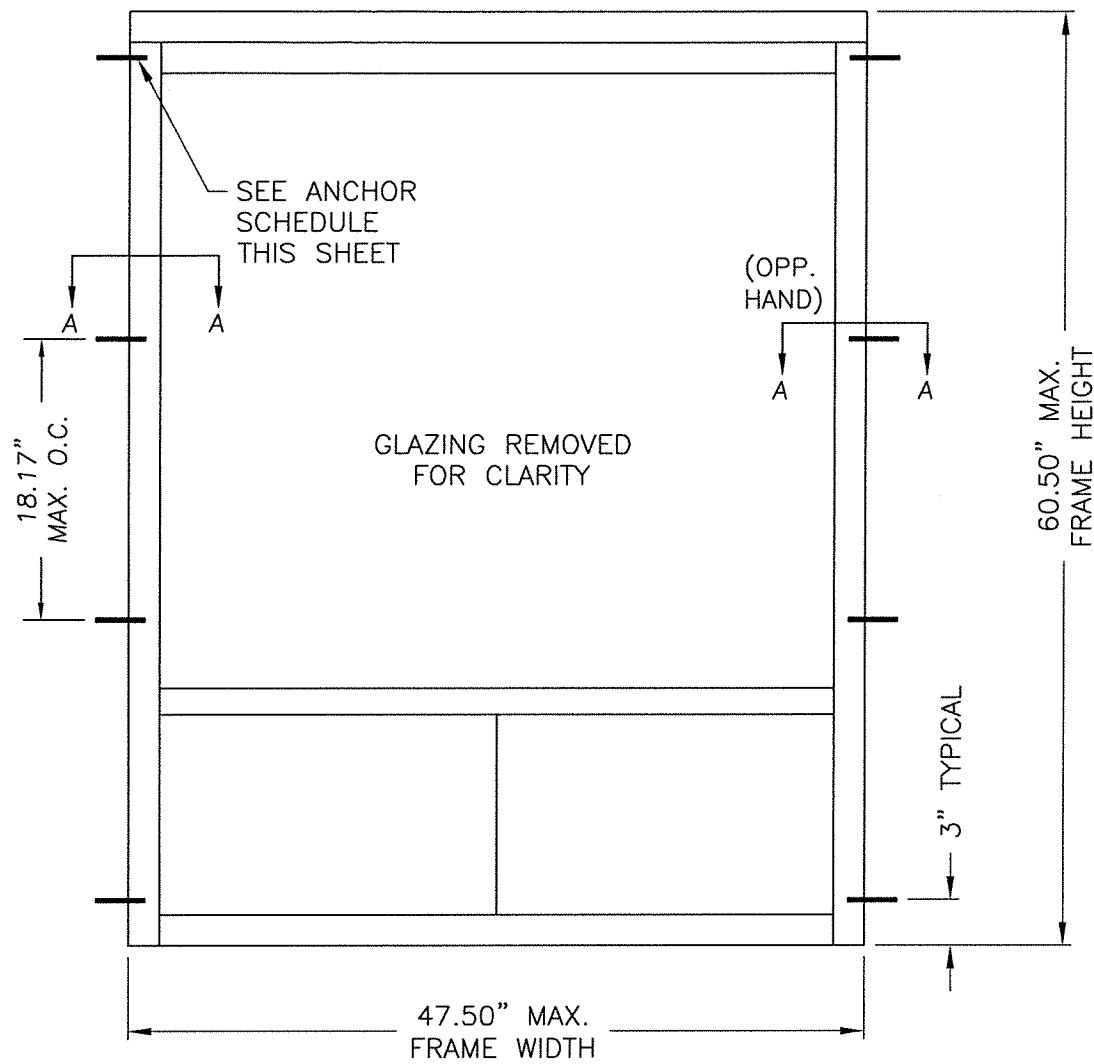

603 AND 604 SERIES WINDOW

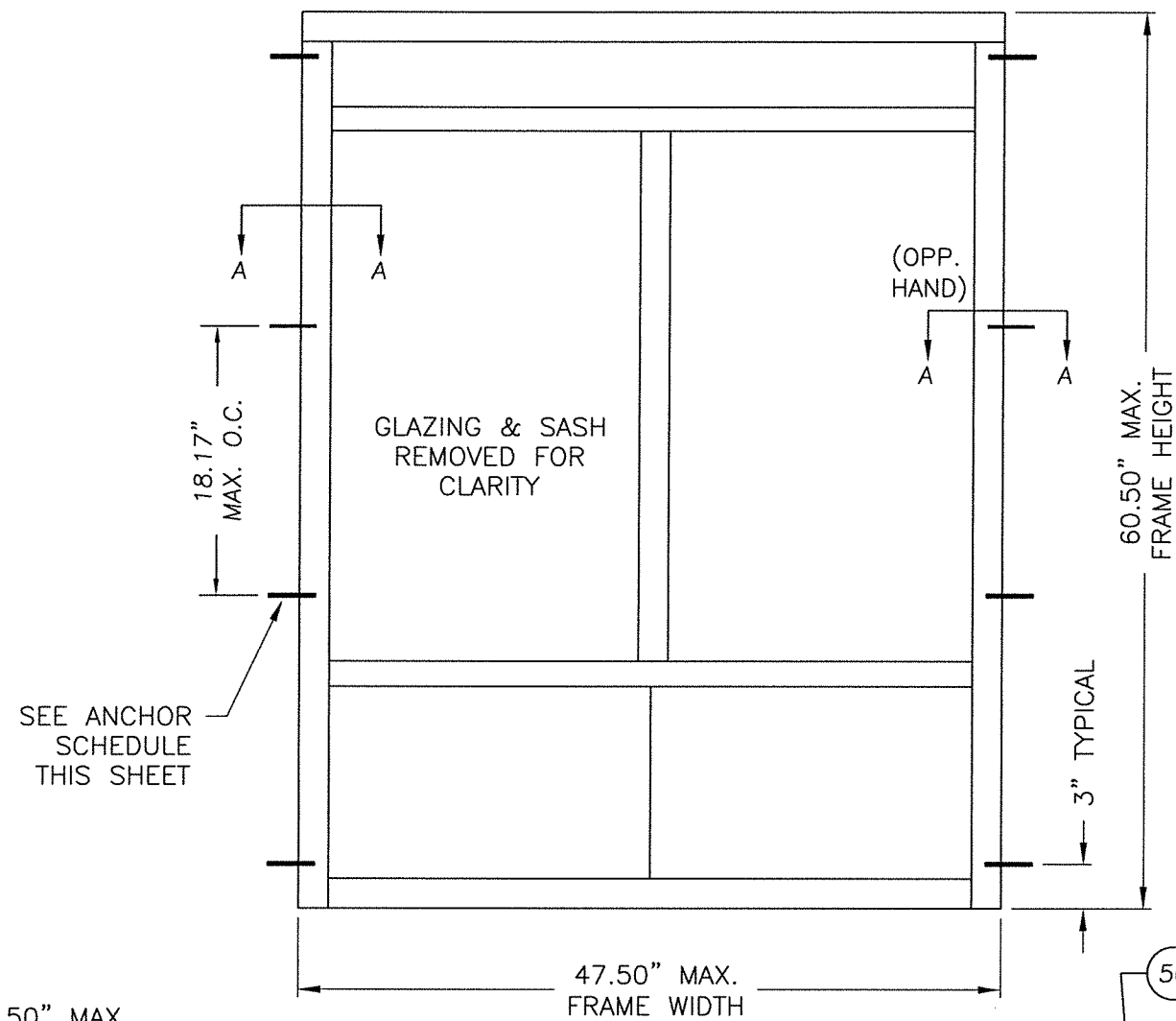

601 AND 602 SERIES WINDOW

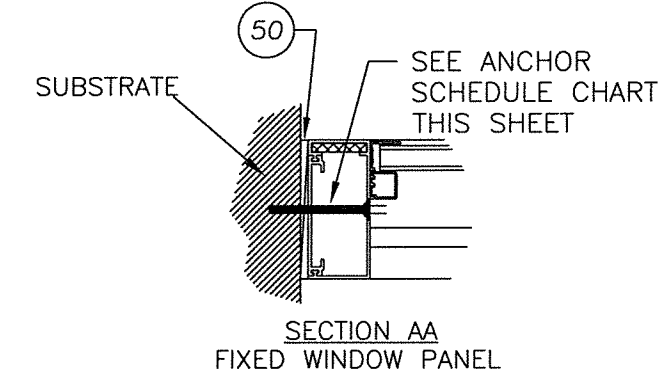

SECTION AA
FIXED WINDOW PANEL

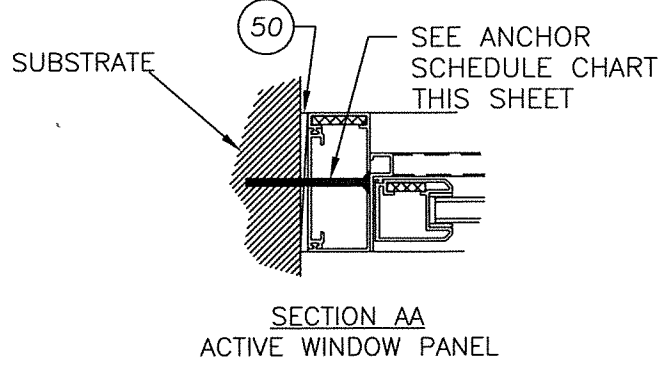

SECTION AA
ACTIVE WINDOW PANEL

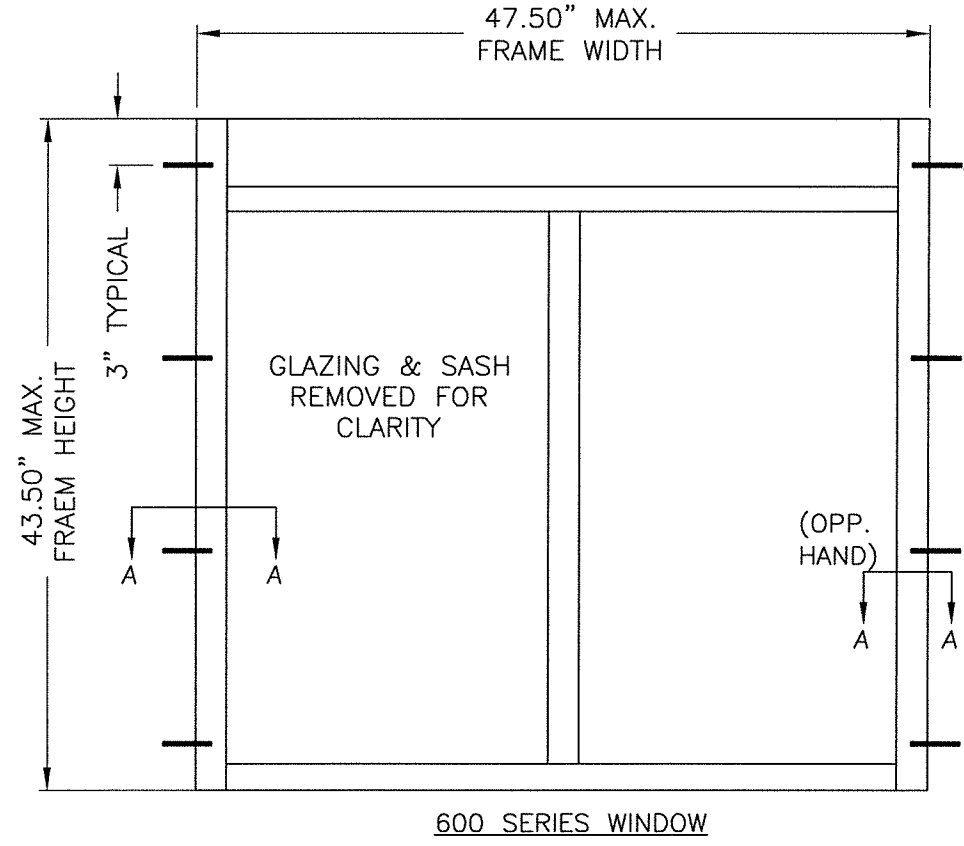

600 SERIES WINDOW

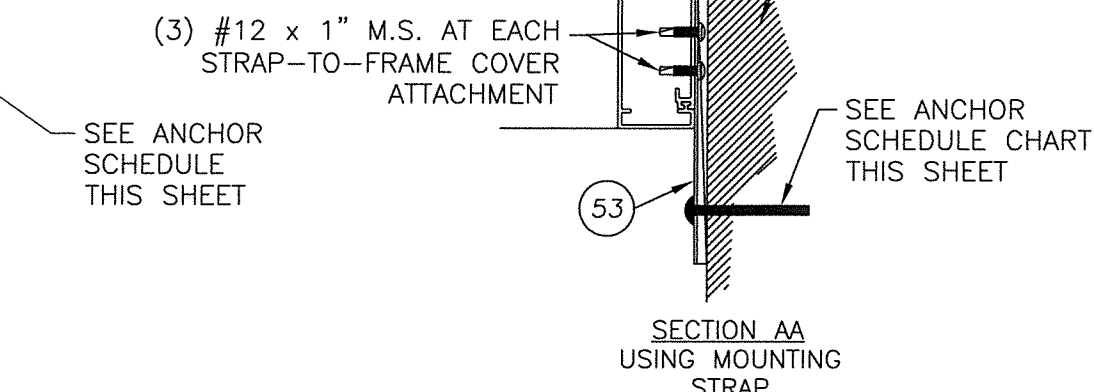

SECTION AA
USING MOUNTING STRAP

ANCHOR SCHEDULE	
SUBSTRATE	ANCHOR
CONCRETE: 3,000 PSI CONCRETE (ACI 301) HOLLOW BLOCK (ASTM C90)	1/4" ϕ HWH ITW TAPCON CONCRETE ANCHOR (1.25" MIN. EMBEDMENT, 2.5" MIN. EDGE DISTANCE & 4" MIN. CL DISTANCE)
STEEL: 16 GA. MIN. (ASTM A36, GRADE 33)	1/4-20 HILTI KWIK-FLEX SELF-DRILLING SMS (MIN. PROTRUSION OF 3 THREADS BEYOND FULL ENGAGEMENT, 3/4" MIN. EDGE DISTANCE & 1" MIN. CL DISTANCE)
WOOD (DOUBLE 2X BUCK): SG = 0.55 OR BETTER	#14 WOOD SCREW (1.75" MIN. EMBEDMENT, 3/4" MIN. EDGE DISTANCE & 1" MIN. CL DISTANCE)

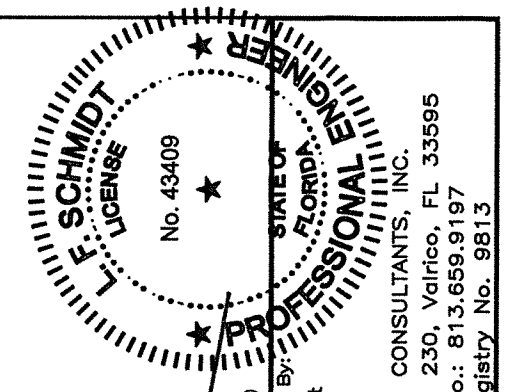

August 7, 2020
 Documents Prepared By:
 Lyndon F. Schmidt
 P.E. No. 43409
 R.W. BUILDING CONSULTANTS, INC.
 P.O. Box 230, Valrico, FL 33595
 Phone No.: 813.659.9197
 FBPE Registry No. 9813

PRODUCT:	READY ACCESS DRIVE THROUGH WINDOW "NON-IMPACT"
PART OR ASSEMBLY:	ANCHORING

NO.	DATE	BY	REVISIONS
3	8/07/20	LFS	UPDATE TO 7TH ED. (2020) FBC
2	7/13/17	LFS	UPDATE TO 6TH ED. (2017) FBC
1	3/30/15	LFS	UPDATE TO 5TH ED. (2014) FBC

DATE: 1/24/12
 SCALE: N.T.S.
 DWG. BY: KV
 CHK. BY: LFS
 DRAWING NO.: FL-5102.4
 SHEET 7 OF 9

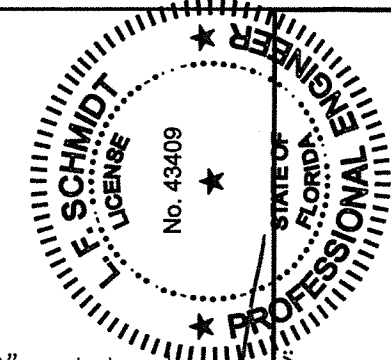
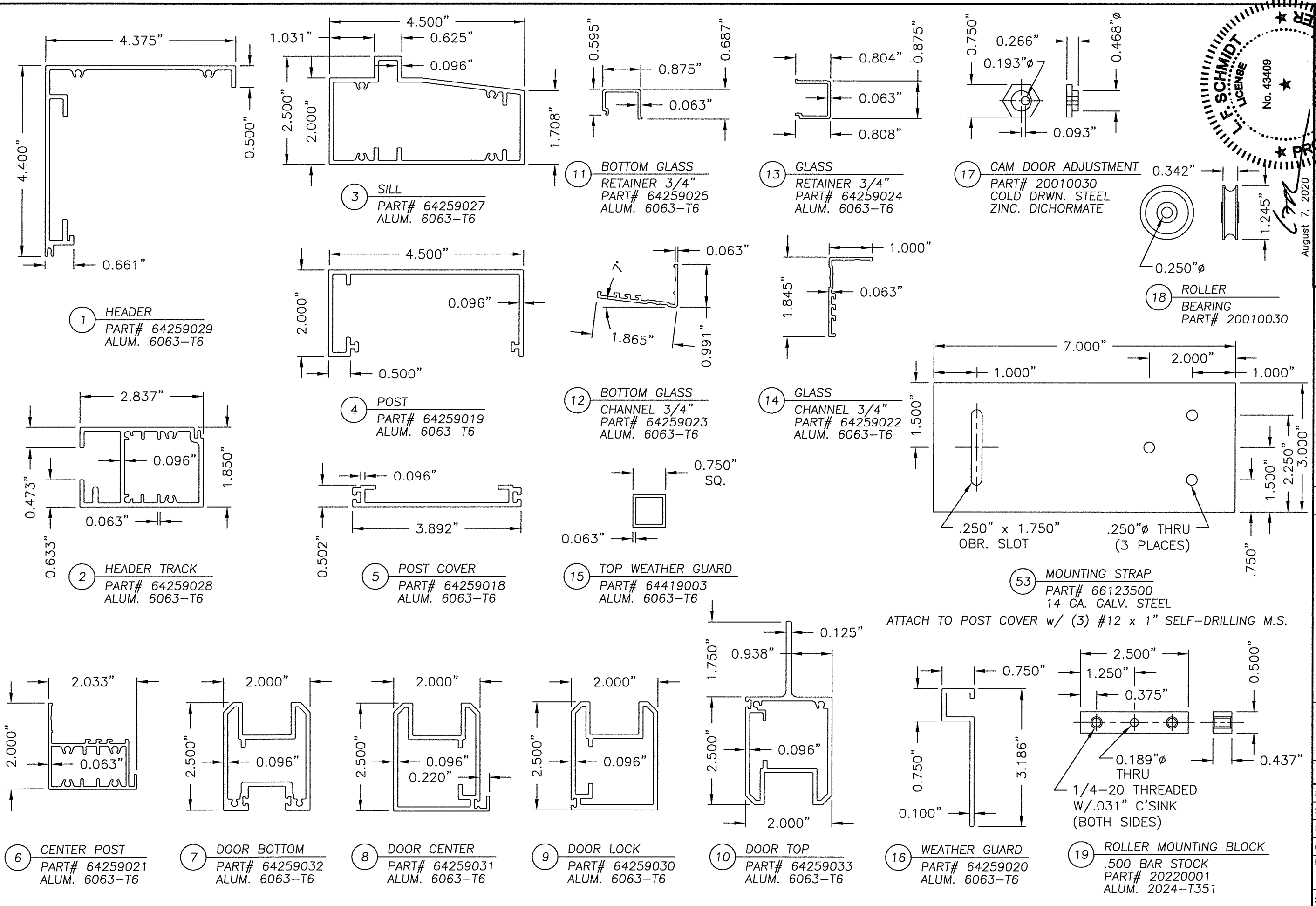

August 7, 2020
 Documents Prepared By:
 Lyndon F. Schmidt
 P.E. No. 43409

R.W. BUILDING CONSULTANTS, INC.
 P.O. Box 230, Valrico, FL 33595
 Phone No.: 813.659.9197
 FBPE Registry No. 9813

PRODUCT:	READY ACCESS DRIVE THROUGH WINDOW
PART OR ASSEMBLY:	"NON-IMPACT" COMPONENTS

NO.	DATE	REVISIONS
3	8/07/20	UPDATE TO 7TH ED. (2020) FBC
2	7/13/17	UPDATE TO 6TH ED. (2017) FBC
1	3/30/15	UPDATE TO 5TH ED. (2014) FBC

DATE:	1/24/12
SCALE:	N.T.S.
DWG. BY:	KV
CHK. BY:	LFS
DRAWING NO.:	FL-5102.4
SHEET	8 OF 9

53 MOUNTING STRAP
 PART# 66123500
 14 GA. GALV. STEEL
 ATTACH TO POST COVER w/ (3) #12 x 1" SELF-DRILLING M.S.

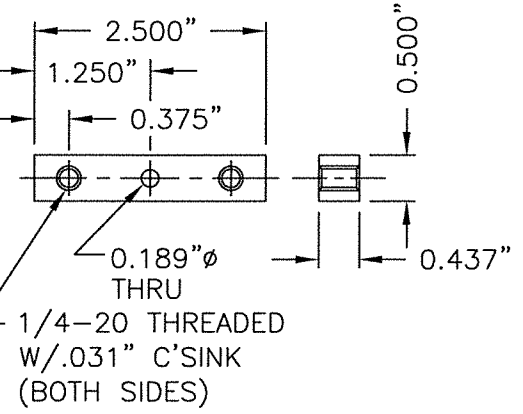

ITEM	DESCRIPTION	MATERIAL
1	HEADER PART# 64259029 ALUM. 6063-T6	ALUM.
2	HEADER TRACK PART# 64259028 ALUM. 6063-T6	ALUM.
3	SILL PART# 64259027 ALUM. 6063-T6	ALUM.
4	POST PART# 64259019 ALUM. 6063-T6	ALUM.
5	POST COVER PART# 64259018 ALUM. 6063-T6	ALUM.
6	CENTER POST PART# 64259021 ALUM. 6063-T6	ALUM.
7	DOOR BOTTOM PART# 64259032 ALUM. 6063-T6	ALUM.
8	DOOR CENTER PART# 64259031 ALUM. 6063-T6	ALUM.
9	DOOR LOCK PART# 64259030 ALUM. 6063-T6	ALUM.
10	DOOR TOP PART# 64259033 ALUM. 6063-T6	ALUM.
11	GLASS RETAINER (3/4") PART# 64259025 ALUM. 6063-T6	ALUM.
12	BOTTOM GLASS CHANNEL (3/4") PART# 64259023 ALUM. 6063-T6	ALUM.
13	GLASS RETAINER (3/4") PART# 64259024 ALUM. 6063-T6	ALUM.
14	GLASS CHANNEL (3/4") PART# 64259022 ALUM. 6063-T6	ALUM.
15	TOP WEATHER GUARD PART# 64419003 ALUM. 6063-T6	ALUM.
16	WEATHER GUARD PART# 64259020 ALUM. 6063-T6	ALUM.
17	CAM DOOR ADJUSTMENT PART# 00651433 STEEL ZINC.	STEEL
18	ROLLER TRACK BEARING PART# 20010030	-
19	ROLLER MOUNTING BLOCK PART# 20220001 ALUM. 2024-T351	TPS
20	CROSS FRAME PART# 64259025 ALUM. 6063-T6	ALUM.
21	SILICONE GLAZING SEALANT DOW 999-A PART# 80050020	SILICONE
22	SELF-LATCHING THUMB TURN PART# 20090081	STEEL
23	PULL HANDLE PART# 65103300	STEEL
24	THUMB TURN DEADBOLT PART# 20090086	STEEL
25	GLAZING FOAM TAPE PART# 20200166	BUTYL
26	RUBBER SEAL "D" SHAPED PART# 40040004	-
27	INSIDE FACE PANEL PART# 66121200	-
28	OUTSIDE FRONT FACE PANEL PART# 56121100	-
29	OUTSIDE SIDE FACE PANEL PART# 66120900	-
30	ARMOR PANEL	-
31	ARMOR STRIP	-
32	GLAZING TAPE 1/2" X .063" PART# 202001155	BUTYL
33	TOP CAP PART# 6122500	-
34	INSULATION PANEL	-
35	COUNTER PART# 96120500	STAIN/STL
37	4X4 GANG BOX	-
38	SPEAKER POWER SUPPLY	-
39	INSIDE MASTER SPEAKER	-
40	OUTSIDE SPEAKER W/HOOKUP WIRE PRE INSTALLED PART# 20110021	-
41	PASS- THRU DRAWER PART# 96130000	-
43	ANGLED SHELF BRACKET	-
44	ROLLER MTG. BOLT 1/4"-20 X 3/4" HEX HEAD MS	-
45	ROLLER MTG. NUT 1/4"-20 NYLON LOCKING NUT	-
46	INSIDE FACE PANEL PART# 66122800	-
47	ARMOR PANEL PART# 66125400	-
50	SHIM 1/4" THK. MAX.	WOOD
53	MOUNTING STRAP (14 ga GALV STEEL)	STEEL

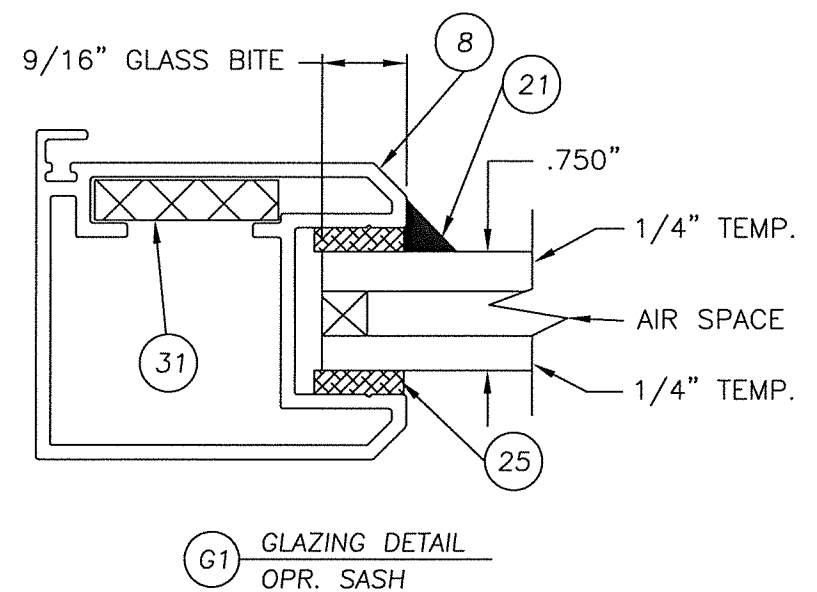
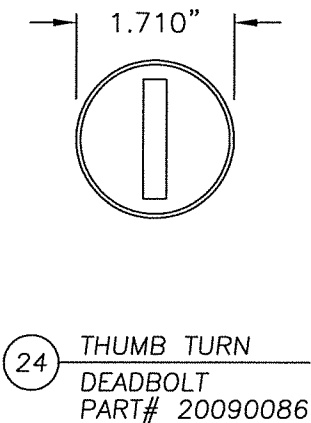
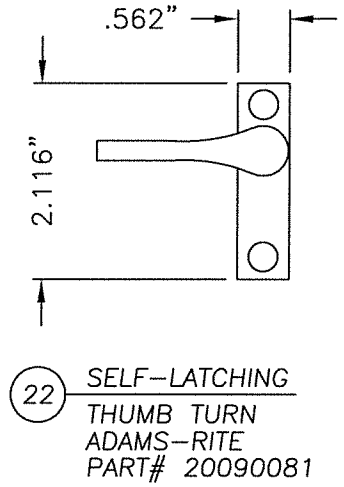
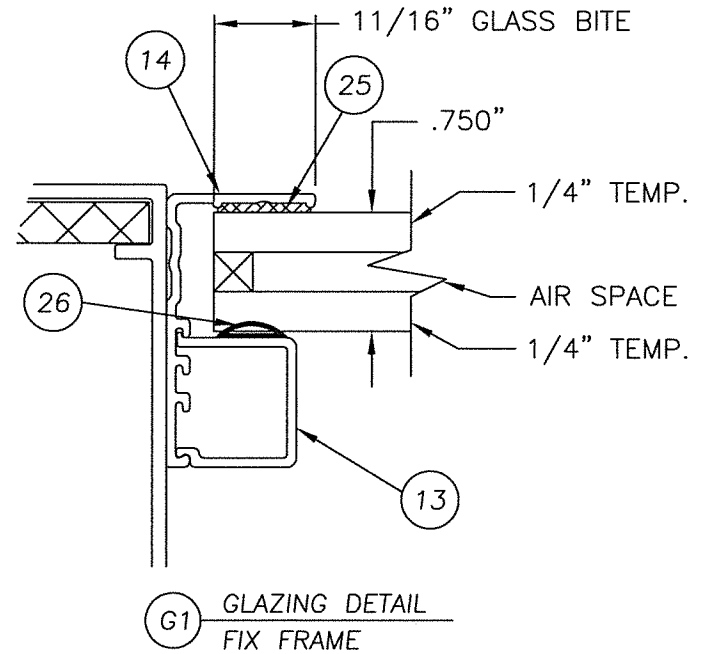
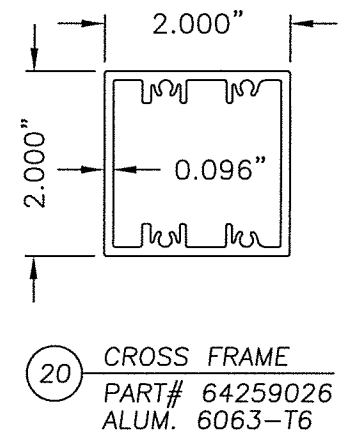
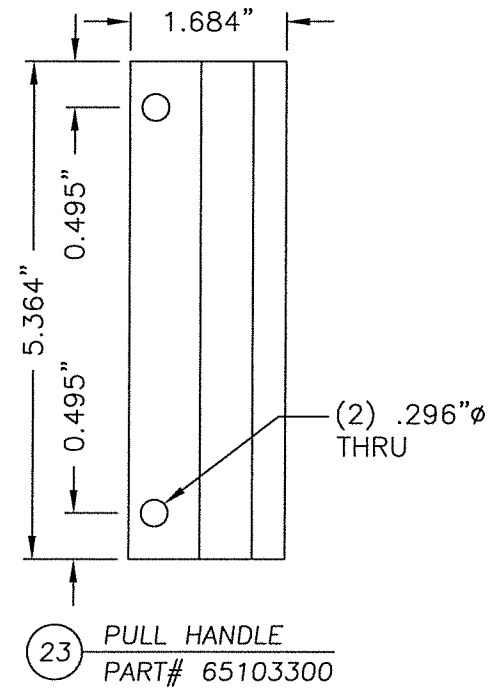

August 7, 2020
 Documents Prepared By: Lyndon F. Schmidt
 P.E. No. 43409
 R.W. BUILDING CONSULTANTS, INC.
 P.O. Box 230, Valrico, FL 33595
 Phone No.: 813.659.9197
 FBPE Registry No. 9813

PRODUCT:		READY ACCESS DRIVE THROUGH WINDOW "NON-IMPACT"	
PART OR ASSEMBLY:		BILL OF MATERIALS, COMPONENTS & GLAZING DETAILS	
	LFS	BY	
4	8/07/20	UPDATE TO 7TH ED. (2020) FBC	
3	7/13/17	UPDATE TO 6TH ED. (2017) FBC	
2	7/13/17	UPDATE TO 6TH ED. (2017) FBC	
1	3/30/15	UPDATE TO 5TH ED. (2014) FBC	
	NO.	DATE	
REVISIONS			
DATE: 1/24/12			
SCALE: N.T.S.			
DWG. BY: KV			
CHK. BY: LFS			
DRAWING NO.: FL-5102.4			
SHEET 9 OF 9			